



**PERFORMANCE ELECTRONICS**

# Installation Instructions

## 320-E LPH FUEL PUMP 100% Gasoline, Ethanol, & Methanol Compatible

### WARNING:

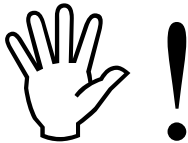

This installation involves changes to your fuel system. If you are not mechanically inclined or do not understand the procedures outlined in these instructions do not attempt the installation. Refer the installation to a reputable mechanic.

#### AEM Performance Electronics

2205 126<sup>th</sup> Street Unit A, Hawthorne, CA. 90250

Phone: (310) 484-2322 Fax: (310) 484-0152

<http://www.aemelectronics.com>

Instruction Part Number: 10-50X

AEM Part Numbers; 50-1200, 50-1205, 50-1210

© 2015 AEM Performance Electronics

## CAUTION!

Installation of the AEM Fuel Pump requires handling of Volatile Fuel. It is imperative that all work is carried out in a well-ventilated area and a fire extinguisher rated for combustible liquid is within easy reach of all personnel working on the fuel system. Extinguish all open flames, prohibit smoking, and eliminate all sources of static electricity or any other source of ignition BEFORE proceeding with installation.

Wear protective clothing, goggles, and gloves rated for fuel. Contact with gasoline, ethanol or methanol is hazardous to your health; ensure that you are well protected from contact with any of these fuels.

The AEM "E" Fuel pump is compatible with gasoline, Ethanol or Methanol and is intended for in tank use. Ensure that the wiring to the pump is correctly insulated and is rated for use in a gasoline tank. Ensure that there is NO possibility of a power lead to the pump contacting a ground in the tank. Use a fused circuit for the pump with a fuse rated at 15 amps.

### AEM Fuel Pump Contents;

Quantity	Description
1	Alcohol Compatible (Ethanol & Methanol) 320 LPH Fuel Pump
1	Alcohol Compatible Electrical connector
1	Pre-filter
1	Fuel Hose
2	Hose Clamps
1	Pump Isolator Sleeve (used in some OEM style applications)
1	Pump End Isolator (used in some OEM style applications)
1	Instructions
1	AEM Decal

This fuel pump is intended for electronic fuel injection systems only. **It is not suitable for carbureted engines.** The fuel pump is an in tank pump and not suitable for external use.

### Pump flow and test information

Every AEM fuel pump is flow tested before it leaves the factory to ensure that it flows nominal 320 LPH @ 43 PSI.\* The flow chart presented below is the result of flow testing 20 fuel pumps, eliminating the highest and lowest flowing samples and averaging the balance of the flow data. The data presented is flow in pounds per hour (PPH), and supported power at various fuel pressure levels. This test data is generated using the AEM E fuel pump, AEM Race Fuel Filter and an AEM universal fuel pressure regulator with the optional .250" return orifice. The pump voltage is 13.5V and the current is 12 Amps for this test. The flow will be different at the engine because of losses through the balance of the fuel delivery system. It is important to ensure that the hoses or lines for the fuel delivery system are clean, not kinked, do not pass hot exhaust components and are terminated correctly. We find inadequate fuel delivery often is the cause of calibration errors that may be detrimental to engine life.

## Power vs. BSFC E-85, E-100 & M-100

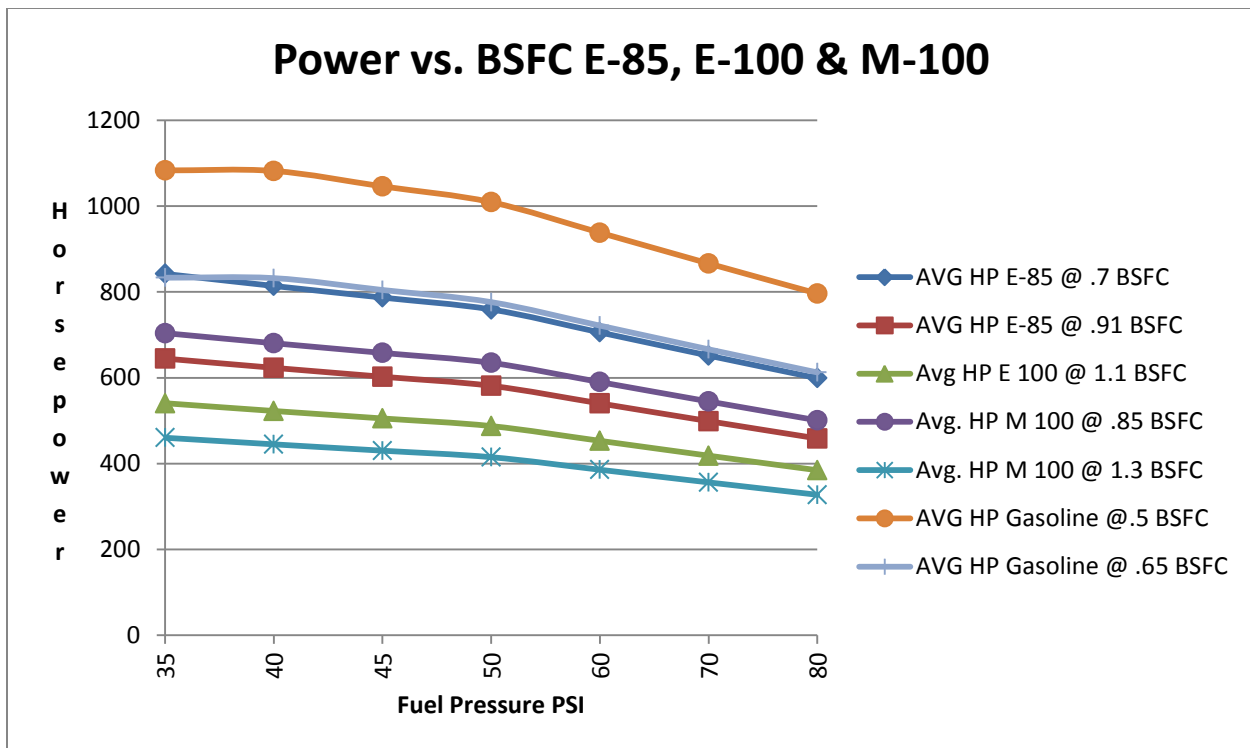

NEVER route fuel hoses through the interior of a car. This is a dangerous thing to do. Whenever possible, use a delivery tube to make the connection from the pump discharge to the filter in the front of the car. The lines should be rated to withstand at least twice the maximum pressure of the EFI system.

**Alcohol based fuels especially 100% strength alcohol fuel burns with a colorless flame. IT IS IMPERATIVE that a thorough leak check is made before the engine is started and there are NO sources of ignition of any type near the work area.**

When routing fuel lines, it is imperative that they are protected from road hazards and exhaust system heat. The fuel line should NEVER be routed near battery cables. Use clamps to secure AN hose every 15 inches, or 24 inches if a rigid tube is used.

The following table will help you determine which hose size is correct for your application: These sizes are based on a nominal fuel pressure of 43 psi.

### Fuel Delivery Hose Sizes

#### Gasoline Powered Engines

Up to 499 HP .344" hose -6AN

500 - 799 HP .437" hose -8 AN

900 – 1100 HP .562" hose -10 AN

E-85 Take above size and multiply by .68 so -6 HP value will support 340 HP

E100 Take above value and multiply by .50 so -6 HP value will support about 250 HP

M-100 Take above value and multiply by .41 so -6 HP value would be 204 HP

The above table should be used for typical passenger car applications. However, for custom applications the hose run length will affect fuel delivery. If you have a long hose run, then the actual flow will have to be determined by running the fuel pump into a graduated cylinder, then measuring the flow vs. time and calculating the flow in gallons per hour (g/h). Also note that if fuel banjos are used in the system be sure they have adequate fuel flow capability.

The fuel return hoses should be one size smaller than the delivery hose. For the engine power levels described above, we would use a .437" (-8) delivery hose and a .344" (-6) return hose.

## Electrical Requirement

The supply voltage will affect the fuel delivery of the AEM Fuel Pump. The typical electrical system on modern cars is between 13.2 – 14.2 volts. Although the AEM fuel pump will run at lower voltages the flow will be lower. **Ensure the voltage is 13.5V at the pump.** The current requirement is minimum 10 amps. The correct wire size will be determined by the length of wire, the wire type and the resistance of any terminals, splices or solder joints in the electrical or ground supply. The ground is equally important and the preferred ground is to route the ground wire to a star ground source that is directly attached to the battery negative post. The **minimum wire gauge** is 12ga. TXL wire. Twelve feet (12') of TOTAL CIRCUIT length (power & ground) 12 ga. is required and Twenty feet (20') 10 ga. is required.

**Before wiring the pump to the electrical system make sure the polarity is correct. Connecting the pump with reverse polarity will damage the pump and is not covered under warranty.**

**Please note; the connector on the AEM 320-E LPH Fuel Pump has a small insulated wire on it between the positive and negative terminals. It must remain place, do not cut it off.**

## Installation Notes

When installing the AEM E pump into a new fuel tank, we recommend that the pump is located in a sump or a chamber where baffling is used to reduce fuel slosh.

**BEFORE STARTING THE VEHICLE, CHECK THE ENTIRE FUEL DELIVERY SYSTEM FOR LEAKS AND REPAIR ANY LEAK BEFORE STARTING THE VEHICLE.**

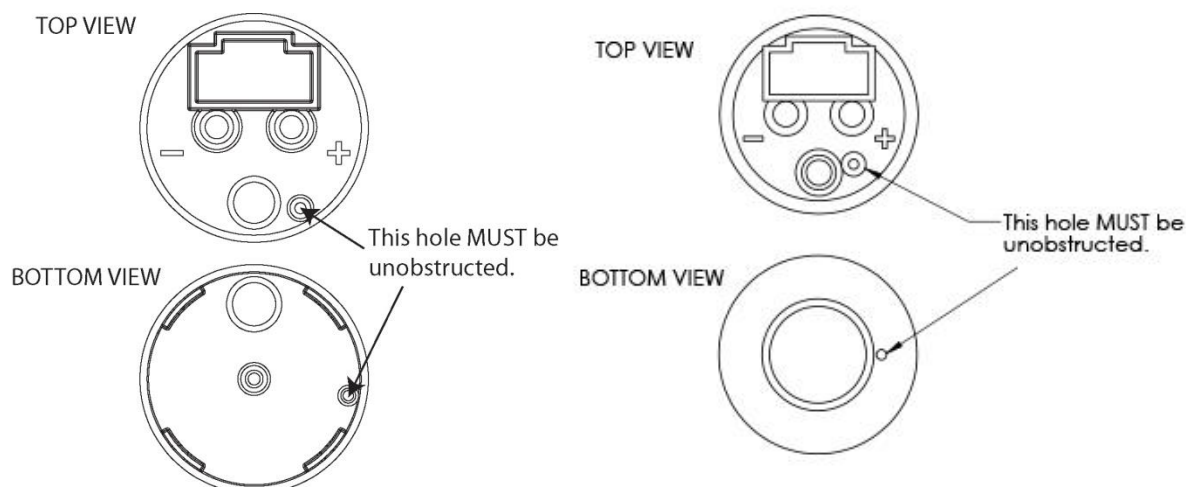

## Warranty

Advanced Engine Management Inc. warrants to the consumer that all AEM Electronics products will be free from defects in material and workmanship for a period of twelve months from date of the original purchase. Products that fail within this 12-month warranty period will be repaired or replaced when determined by AEM that the product failed due to defects in material or workmanship. This warranty is limited to the repair or replacement of the AEM part. In no event shall this warranty exceed the original purchase price of the AEM part nor shall AEM be responsible for special, incidental or consequential damages or cost incurred due to the failure of this product. Warranty claims to AEM must be transportation prepaid and accompanied with dated proof of purchase. This warranty applies only to the original purchaser of product and is non-transferable. All implied warranties shall be limited in duration to the said 12-month warranty period. Improper use or installation, accident, abuse, unauthorized repairs or alterations voids this warranty.

AEM disclaims any liability for consequential damages due to breach of any written or implied warranty on all products manufactured by AEM. Warranty returns will only be accepted by AEM when accompanied by a valid Return Merchandise Authorization (RMA) number. Product must be received by AEM within 30 days of the date the RMA is issued.

Please note that before AEM can issue an RMA for any electronic product, it is first necessary for the installer or end user to contact the tech line at 1-800-423-0046 to discuss the problem. Most issues can be resolved over the phone. Under no circumstances should a system be returned or a RMA requested before the above process transpires.

AEM will not be responsible for electronic products that are installed incorrectly, installed in a non-approved application, misused, or tampered with. In the case of the AEM Fuel Pump, incorrect polarity (+&- wires crossed) will not be warranted.

Proper fuel filtration before and after the fuel pump are essential to fuel pump life. Any pump returned with contamination will not be warranted.

Any AEM electronics product can be returned for repair if it is out of the warranty period. There is a minimum charge of \$50.00 for inspection and diagnosis of AEM electronic parts. Parts used in the repair of AEM electronic components will be extra. AEM will provide an estimate of repairs and receive written or electronic authorization before repairs are made to the product.

Need additional help? Contact the AEM Performance Electronics tech department at 1-800-423-0046 or tech@aempower.com, or visit the AEM Performance Electronics forum at <http://forum.aempower.com/forum/>