

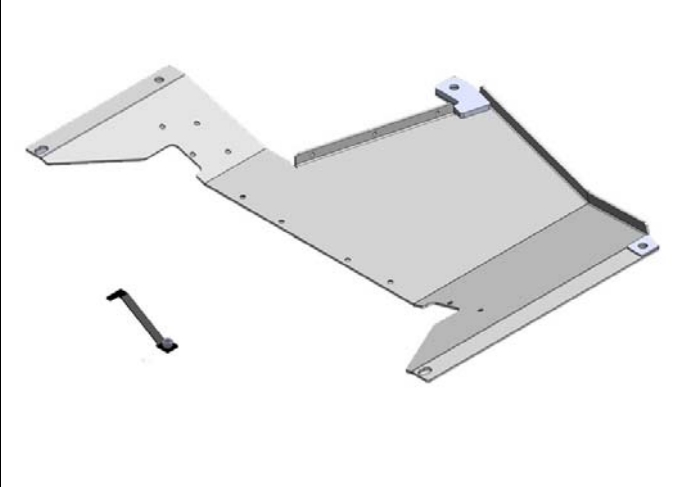

Thank you for purchasing a Clayton Off Road suspension.

Please check to make sure you have all necessary parts before you start your install.

4108100 – JK Transfer Case Skid Plate		
1	4108100	Transfer Case Skid Plate
1	JKTCSP05	1/8" Skid Plate Nut Bracket
1	19959	1/2-13 x 1-1/2 Case Hardened Zinc Flange Bolt
8	94286	3/8"-16x1" Flat Head Socket Cap Screw
2	94288	3/8"-16 x 1-1/2" Flat Socket Cap Screw
2	33815	3/8" SAE Flat Washer Yellow Zinc
2	36406	3/8"-16 Hex Nut Grade 8



If you are missing any of the above items, or are unclear about what parts you need, please call and ask before you begin your installation process.

Clayton Off Road Inc. – 1261 Meriden Road – Waterbury – CT – 06705 – (203) 757-0339 sales@claytonoffroad.com

Note : This skid plate was designed to be used with our JK 3 piece cross member (PN 2108100) or our JK HD cross member (PN 2108200). It does NOT match up to the factory holes in the OE cross member.

Note: You will be required to drill one 1/2" hole in the passenger side frame rail to properly attach this skid plate.

Note: You will be required to trim the factory gas tank skid plate.

WARNING: Suspension systems and their components are designed to enhance your vehicles off-road performance. This may cause your vehicle to handle differently, on and off-road, then it did from the factory. Always wear your seatbelts, and take extra care when driving a modified vehicle. Failure to do so can result in loss of control which may result in a rollover causing serious injury, even death to the driver and/or passengers of the vehicle. Regular maintenance and constant inspections are required to keep your modified vehicle safe and function properly.

These systems and any components should be installed by certified technicians. Attempts to install these products without proper knowledge can lead to poor performance, or possible failure, which may jeopardize the safety of the vehicle and its passengers. The installer is responsible for proper installation insuring a safe and properly functioning vehicle. Take extra care when operating a modified vehicle and thoroughly inspect your vehicle before and after every off-road use.

Please read the entire instruction manual before starting the installation. If anything is unclear, please contact us before starting your installation.

Contact at: (203) 757-0339 or email sales@claytonoffroad.com

Tool requirements

1. Normal shop tools, wrench and allen keys.
2. 1/2" drill bit and electric drill
3. Cut off wheel, sawzaw or hack saw.

Installation Manual
Transfer Case Skid Plate
2007 – 2011 Jeep Wrangler & Unlimited
Last Revision No.: 1/10/12
PN – 4108100

JK Skid plate Installation:

1. Remove OEM skid plate.
2. The OEM gas tank skid plate should be trimmed to clear our cross member. The stock gas tank skid has 4 holes in the front passenger side. You will need to trim the front 2 holes off, so that it does not interfere with the new cross member.



- 3.
4. The new skid plate will attach to the cross member, and bolt through the remaining gas tank skid plate holes.
5. If you are using our 3 piece long arm cross member, remove the corresponding allen head bolts.
6. Install skid plate starting with the four 3/8" allen head bolts in the center of the cross member. Do NOT fully tighten.
7. Next you will install the four outside 3/8" allen head bolts. Do NOT fully tighten.
8. Now install the two driver side OE bolts in the stock location, the one passenger side bolt, and one gas tank mount bolt.
9. Fully tighten all eight allen head bolts, and all OE bolts.
10. Drill a 1/2" hole using the skid plate as a template in the passenger side frame rail.
11. Install skid plate nut bracket into the frame hole with the pem fastener facing in, and the tab facing up, as shown below.



- 12.
13. Carefully line up the bracket with the 1/2"-13 flange bolt, and tighten.
14. Using the 2 longer 3/8" allen head bolts, washer and nut, secure the new skid plate to the OE gas tank skid plate. You may need to drill out the holes to properly line up the holes if your skid has shifted or if you are using an aftermarket setup.
15. Check for any clearance issues, and double check to make sure all bolts are tight.

Hope your installation went smoothly. Please let us know if you have any questions, comments or concerns.

Installation Manual
Transfer Case Skid Plate
2007 – 2011 Jeep Wrangler & Unlimited
Last Revision No.: 1/10/12
PN – 4108100

Damage or Missing Parts Policy: If you receive a product that is damaged or missing parts you must contact us within 14 days to arrange replacement. You may be required to submit photos of damaged parts before new parts are sent. Damage parts may be required to be returned for inspection.

Return Policy: You have 30 days to return a product in its original packaging. Parts cannot have been installed, painted and/or modified in any way. You must contact us to obtain a RGA # (Return Goods Authorization) before shipping your product back. All returns are subject to a 15% restocking fee. Your return must have the return authorization number clearly marked on the outside of the package and must be shipped prepaid. Packages shipped COD will be refused. Returns are subject to inspection and may be refused if they are damaged or used. You are responsible for proper shipping to ensure product is not damaged or lost. We recommend insuring your product for the full amount in the case it is damaged or lost during return shipment.

Warranty Policy: Clayton Off Road Inc. comes with our abuse proof limited lifetime warranty against bending or breaking our control arms only. This covers the original purchaser of our suspension lift. This warranty cannot be transferred to a secondary purchaser and is void if the control arm is modified in any form or not used in its proper application. Original purchaser must obtain a RGA # and is responsible for shipping the product back and agrees to return shipment charges. This warranty does not cover worn bushings, missing snap rings, or any kind of rust damage to the threads or inserts or actual arm.

What is not covered:

Clayton Off Road Inc. components may have minor finish damage to powder coated or plated surfaces, which may occur during shipping and is not covered under warranty. Johnny Joint bushings, washers, snap rings, OEM rubber bushings, hardware, brake lines, shocks, springs, skid plates, trackbars, and any mounting brackets are not covered. These parts are subject to wear and are not considered defective when worn. They are warranted for 90 days from the date of purchase for defects in workmanship only. Products or components which have been subjected to abuse, accident, alteration, modification, improper installation, tampering, negligence, misuse, or products installed on a vehicle used in sanctioned racing events. A race is defined as any contest between two or more vehicles, or any contest of one or more vehicles against the clock, whether or not such contest is for a prize.

Clayton Off Road Inc. is not responsible for any retail parts that may be sold.

Clayton Off Road Inc. shall not be liable for any loss, damage or injury, whether ordinary, direct, special, incidental or consequential damages, arising from the manufacture, sale, installation, resale, delivery, possession, handling or use of its products.

Clayton Off Road Inc. is not responsible for typographical errors either in pricing or in content.

Warranties, policies and prices subject to change without notice.

ALL CLAYTON OFF ROAD INC. PRODUCTS ARE FOR OFF ROAD USE ONLY!